

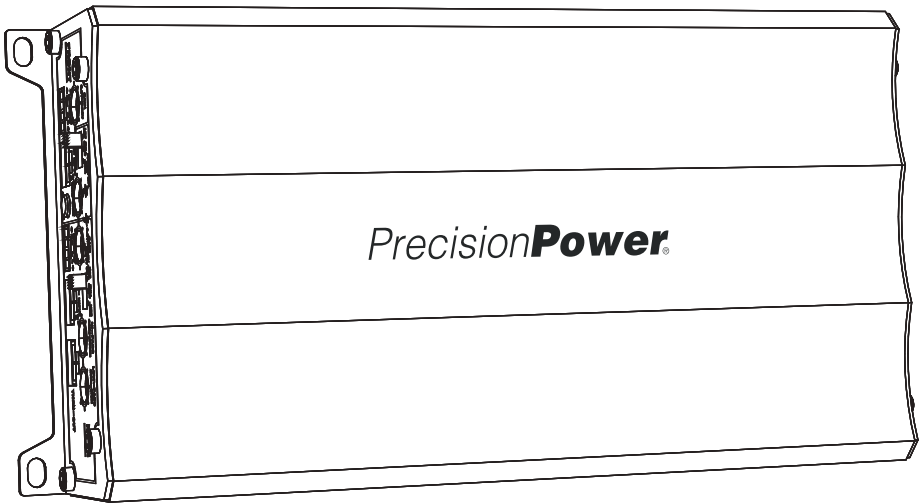

# PrecisionPower®

Absolutely State of the Art Mobile Audio™

## CLASS D 4-CHANNEL AMPLIFIER



PrecisionPower®

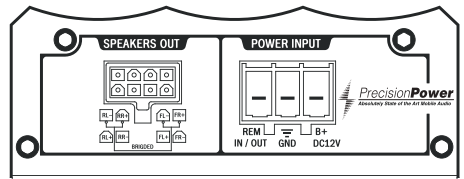
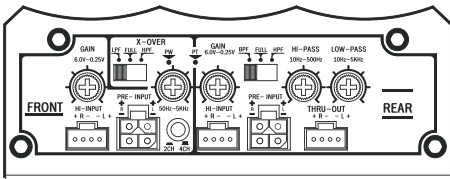

Scan With Your Phone's Camera To Learn  
More About This & Other Motorcycle  
Audio Products by PrecisionPower



<b>Introduction</b>	<b>3</b>
<b>Features &amp; Specifications</b>	<b>4</b>
<b>End Panel Diagrams</b>	<b>5</b>
<b>Input / Output &amp; Pre-Amp Controls</b>	
<b>Low-Level / RCA Input</b>	<b>6</b>
<b>High-Level Input</b>	<b>6</b>
<b>Input Modde Switch</b>	<b>6</b>
<b>Thru-out Output</b>	<b>6</b>
<b>Gain / Level Adjustment</b>	<b>6</b>
<b>Crossover Filter Selector Switch</b>	<b>7</b>
<b>High-Pass Crossover Filter</b>	<b>7</b>
<b>Low-Pass Crossover Filter</b>	<b>7</b>
<b>Power &amp; Protection Indicators</b>	<b>8</b>
<b>Speaker Output</b>	<b>8</b>
<b>Power / Ground Input</b>	<b>8</b>
<b>Amp Installation</b>	<b>9</b>
<b>Power &amp; Ground Cable</b>	<b>10</b>
<b>Remote Turn-on</b>	<b>11</b>
<b>Low-Level / RCA Input</b>	<b>11</b>
<b>High-Level / Speaker-Level Input</b>	<b>11</b>
<b>Speaker Output</b>	<b>12</b>
<b>Amp Installation Diagrams</b>	<b>13</b>
<b>Troubleshooting</b>	<b>15</b>
<b>Warranty</b>	<b>16</b>

**Caution**

*PrecisionPower* amplifiers are capable of producing sound pressure levels that will rock your world. High sound pressure levels combined with prolonged listening can give permanent damage to your ears. Choose a listening level that is comfortable.

## Welcome to The Realm of *PrecisionPower!*

Absolutely State of the Art Mobile Audio

As one of the revolutionary companies of high-end car audio dating back over 4 decades, *PrecisionPower* dominated the sound quality competition arenas. Back in the day, PPI manufactured amplifiers only and were frequently accompanied by a high-end imported components and high-end subwoofers.

The market changed fundamentally in the last 3 or 4 decades. Today, there is no shortage of car audio companies, but many are slowly fading away. 2020 not only brings you a brand new *PrecisionPower* company, but a long-awaited return of elite sound quality car audio products. Amplifiers, components, subwoofers and full range speakers, everything you need to experience sonic nirvana!

## Sonic Goals

Everybody loves great sounding music. Some audiophiles live for it while others, not so much. Some people feel that certain amplifiers are better suited for Jazz, while others seem more at home with rock-n-roll. They're right; every amplifier has a distinctive sound. Some could argue it's due to the pre-amp/input section, other times is the output classification. Sometimes it is the magic within the power supply. There is no shortage of amplifier manufacturers for all realms of audio. Each has their own theories on what materials are best, what specifications work best for certain applications, etc. There are still some very old amplifiers still in existence and they still sound phenomenal. However, as technology changes, new and exciting products can be fabricated.

*PrecisionPower* motorcycle audio amplifiers adopt class D architecture, commonly mistaken as a digital amplifier (sorry flat-earthers, class D is an analog technology). What does it all mean? Class D, invented in the 1950's & made popular in the 1980's, refers to the switching frequency of the output devices. The MOSFETs (Metal-Oxide Semi-conductor Field Effect Transistors, btw) operate as electronic switches, not as linear gain devices as in other amplifier technology. They operate by rapidly switching back and forth between the power supply rail voltage, encoding the original audio signal by a pulse width modulator. It's thanks to this ultra-sonic switching that gives class D it's typical 90% efficiency.

Some will argue other amplifier classifications have better or different sonic qualities, here again, they might be right. However, class D has matured immensely in recent years, shedding it's old "dirty power" reputation. Proving itself a contender for sound quality, some are willing to reap the benefits of class D's smaller footprint and staggering increase in efficiency. We could go further down the rabbit hole but let's get on to the fun stuff....

*Precision**Power*** motorcycle audio amplifiers adopt the most exemplary Korean Class-D engineering & performance. Once regarded as “dirty power,” class D stable performance rivals traditional full range applications. It’s greatest advantage is very little energy lost as dissipated heat, allowing efficiency to reach 90%. Less heat dissipation means less heatsink, allowing this small and powerful amp to fit inside your motorcycle’s fairing. All pre-amp & crossover options are conveniently located on one side of this amplifier, while quick-disconnect connection plugs for power and speaker outputs are on the other. We know you want it loud...

**MAA4.400**

- 2-Ohm Stereo & 4-ohm Bridged Stable Amplifier
- State-of-the-Art Class D IC Amplifier Technology
- Hybrid Aluminum Alloy Heatsink for Heat Dissipation
- Quick Disconnect 8g Power & 14g Speaker Wire Harness
- 200mV-6V Low-Level RCA Input Harnesses Included
- Signal Sensing Turn-On on Hi/Speaker Level Input
- Optional Variable 12dB/Octave High-Pass Crossovers
- Optional Variable 12dB/Octave Low-Pass / Band-Pass Crossover
- Low Level RCA Output Harness for Daisy Chained Applications
- 100W X 4Ch (4 $\Omega$ , 14.4V, 1KHz,  $\leq$  1% THD+N)
- 150W X 4Ch (2 $\Omega$ , 14.4V, 1KHz,  $\leq$  1% THD+N)
- Dimensions: 5.375”w x 1.875”h x 9.25”l
- Works w/ *Precision**Power*** Amplifier Installation Kits

Left Side

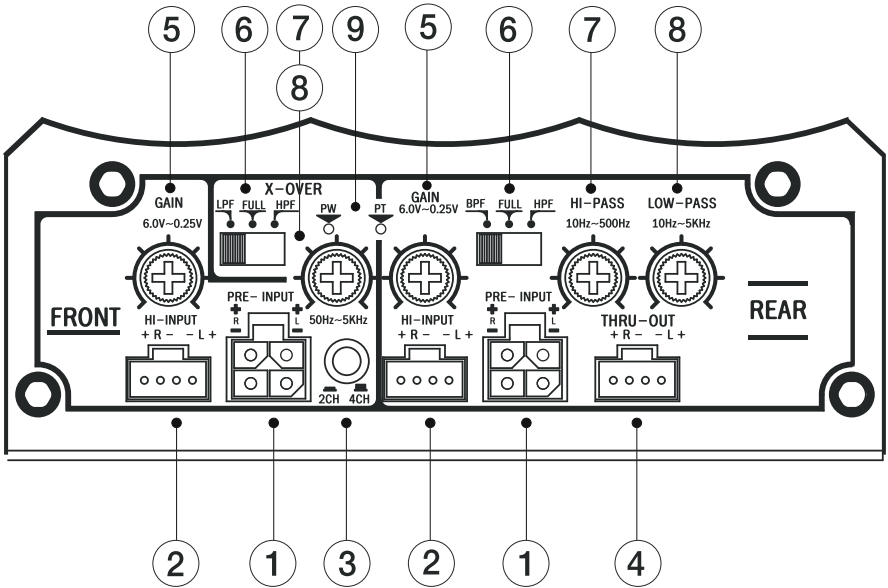

Right Side

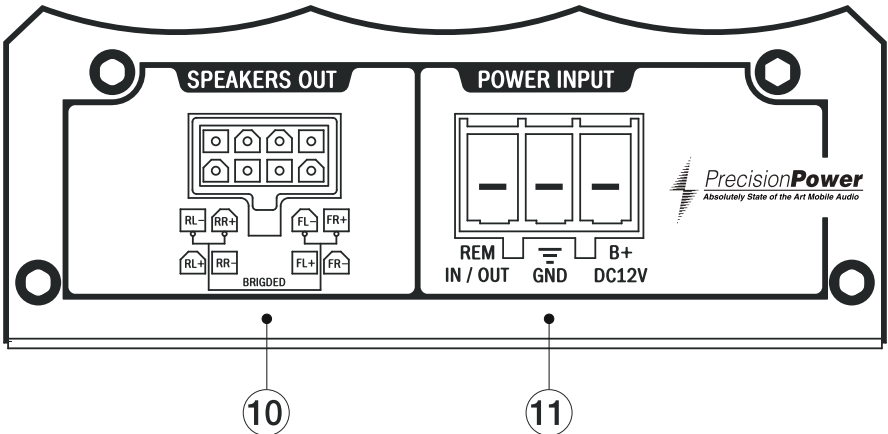

**1. Low-Level / RCA Input**

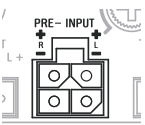

We've provided RCA input harness for this amplifier, in the event you are using an aftermarket head unit with RCA outputs, and you feel very strongly about noisy sound & ground loop noises. Really though, low voltage signal from RCA outputs is susceptible to noise from the various electronic components & wiring in the fairing. Even nearby LED lighting can introduce noise. In the event you are using an aftermarket head unit with RCA outputs, we still recommend using high/speaker level input from it.

**2. High-Level Input**

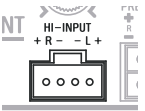

This amplifier can receive signal from the head unit's high-level speaker output. Using hi-level (speaker-level) input is a much better choice than low-level/RCA. High level signal rejects noise from surrounding electronics like LED lights and high current power wires. Additionally, the amplifier will operate more efficiently and cooler with high-level input.

**3. Input Mode Switch**

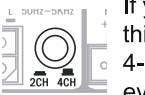

If you're installing this amp with a factory head unit & 2-speaker system, push this button in. If something explodes, run. If you have a factory head unit & 4-speaker system, depress this button out. Since you are smarter than everyone else and you're using Soundstream Reserve's HDHU.14+ head unit, leave the input selector switch out for 4-channel input. Oh, you're using a different aftermarket head unit, we're sorry to hear that. *UPGRADE YOUR LIFE!!!*

**4. Thru-out Output**



Thru-out output is an unfiltered output to connect multiple amplifiers together. Commonly referred to as daisy-chain, this output can be connected to other amplifiers via RCA cables or high-level input cables provided. If you are using low-level / RCA input, the thru-out signal is also low-level for RCA. However, if you are using high level input, (as you will be using the amplifier installation kit) the amplifier converts the thru-out signal to low-level for RCA cables.

**5. Gain/Level Adjustment**



Nope, not a volume control, not even a little bit. Your primal instincts might tell you to crank it to 100%, but that's not the right answer. Gain/level is meant to adjust the amplitude of the speakers powered by the amplifier to match the amplitude of other speakers and/or subwoofers within a complete system. If all speakers on your bike are powered by this amp, there's nothing to fear. Increase the volume level of the head unit until you hear distortion in the music. If you're not sure what to listen for, increasing the volume to about 75% of maximum is a good starting point. Then, increase the gain of the amplifier until you hear bad noises, or until reaching a comfortable listening level. You can use the gain for front & rear to level match between multiple sets of speakers, like in tour pak or lower fairings.

## 6. Crossover Filter Selector Switch

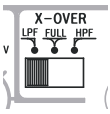

Crossovers are here for your protection. Well, at least for your speakers. Some speakers are engineered for optimum performance in various frequency ranges. Playing music with frequencies outside of the speakers limitations will result in distorted sound, and/or cause damage to its components.

**HPF** - The High-Pass Filter will pass frequencies higher than (block frequencies lower than) the setting. You might use the high-pass filter for speakers in the fairing, tour pak, lower fairing, or saddlebag lid to block lower bass frequencies; they're not subwoofers...

**LPF** - The Low-Pass Filter will pass frequencies lower than (block frequencies higher than) the setting. Low-pass crossovers are more commonly used when powering the woofer of a component set, or a subwoofer.

**FULL** - Full deactivates all crossover circuitry so all frequencies will pass. If you're using good quality speakers, (any from *PrecisionPower*, btw) they should handle full range sound, within reason. Keep in mind though, full range provides no protection to your speakers, so consider using even the minimum high-pass crossover setting to block the super low bass frequencies. Really though, with the bike running and at riding speed, you won't hear those super low bass frequencies anyway.

**BPF** - Band-Pass Filter activates both high-pass & low-pass crossovers simultaneously, passing only frequencies between the two settings. BPF is used in more custom applications where midrange speakers are used, with separate tweeters and subwoofer(s), etc. Band-pass filter is available only on the rear channels (ch. 3 & ch. 4). Please consult with a *PrecisionPower* dealer for help with more advanced, custom audio systems.

## 7. High-Pass Crossover Filter

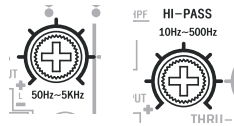

The HPF dial sets the high-pass crossover frequency. The range is from 50-5,000Hz for the front channels (ch. 1 & ch. 2), and 10-500Hz for the rear channels (ch. 3 & ch. 4).

## 8. Low-Pass Crossover Filter

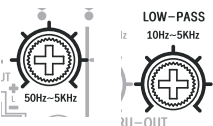

The LPF dial sets the low-pass crossover frequency. The range is from 50-5,000Hz for the front channels (ch 1 & ch. 2), and 10-5,000Hz for the rear channels (ch. 3 & ch. 4).

**9. Power & Protection Indicators**

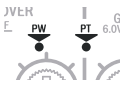

The power indicator (PW) indicator will illuminate blue when the amplifier is on and operating normally. The protect indicator (PT) will illuminate red momentarily during initial power-up. If the protect indicator illuminates red constantly, there is a fault in the wiring, a direct short, etc. that is causing the amplifier to enter it's self-preservation mode. See the Troubleshooting section in this manual for diagnosis.

**10. Speaker Output**

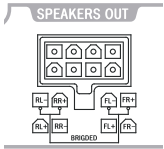

The speaker outputs are conveniently bundled together onto one connector. This makes removal after installation less inconvenient, should you need to remove the amplifier for any service, accessory installation, etc.

**11. Power/Ground Input**

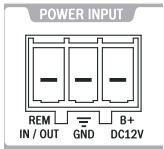

This amplifier includes a connector for 8-gauge power and ground wires, and a remote turn-on wire. Securing power & ground wires to this connector makes removal of the amplifier after installation less inconvenient, should you need to remove the amplifier for any service, accessory installation, etc.



Installing amplifiers requires detailed knowledge of electronics wiring & proper speaker impedance. We strongly recommend installation by an authorized dealer. This owners manual provides only general installation and operation instructions. If you have any reservations about your installation skills, there's no shame in visiting [MotorcycleAudio.com/specialist-locator](http://MotorcycleAudio.com/specialist-locator) to locate a local dealer. Unfortunately, watching a few videos online and/or reading this owner manual will not make you a master installer.

If you're still reading, then you've chosen to give it the ol' college try, good for you... There are a few ways you could install this amplifier in your bike; in the fairing, in the saddlebag, etc. We won't get into details about those, as every installation could be different. However, we'll go over general installation instructions. Hopefully you've been smart enough to acquire a **PrecisionPower** amplifier installation kit appropriate for your bike, right? No? What are you doing with your life? Who hurt you?

Get **PrecisionPower** [HD14.AWK](#) for 2014+ or [HD13.AWK](#) for 1998-2013 bikes and follow the very detailed instructions it comes with. The kit includes any/all brackets & hardware you will need to securely install this amp into the fairing. It also includes power/ground wires to connect to the battery & a plug-n-play T-harness that connects to the head unit to steal audio signal without cutting & splicing wires. Work smarter, not harder.

Scan With Your Phone's Camera To Learn More About Our Amplifier Installation Kits for Harley Davidson Motorcycles



Or Visit [MotorcycleAudio.com/Amplifiers](http://MotorcycleAudio.com/Amplifiers)

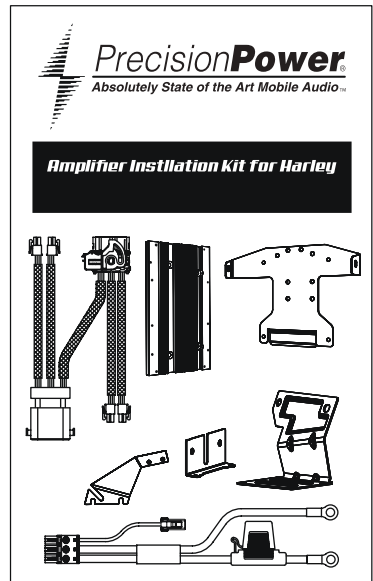

Lets talk about the elephant in the room; your head unit. If you're choosing to keep your factory head unit, it's ok, we won't judge you publicly. However, we do recommend you have your factory head unit flashed, to rid it of evil EQ curves and activate all channel outputs. Most **PrecisionPower** dealers have magic wands to perform such wizardry. Drop your zip code in our super convenient dealer locator to find a sorcerer nearest you: [MotorcycleAudio.com/specialist-locator](http://MotorcycleAudio.com/specialist-locator). Go, now....

These amplifiers are designed to work with a 10V to 16V Direct Current (DC) charging system. Before any wires are connected, the motorcycle's electrical system should be checked for correct voltage supply with the help of a voltmeter. Check the voltage at the battery with the ignition in the OFF position. The voltmeter should read no less than 12V. If your bike's electrical system is not up to these specifications, we recommend having it checked by an auto electrician before any further installation.

### **POWER & GROUND WIRE/CABLE**

This amplifier should be wired directly to the motorcycle's battery using good quality 8-gauge stranded wire. The use of a 50A in-line fuse or circuit breaker is a must; this will prevent the risk of a potential fire caused by a short in the power cable. Connect the fuse holder or circuit breaker as close to the battery positive terminal as possible, about 18" from the battery. If you're using the amplifier installation kit, it includes the fuse holder, 50A fuse, and ring terminals crimped-on for the battery terminals.

**DO NOT GROUND THE AMPLIFIER TO THE FRAME!!! PLEASE ROUTE A DEDICATED 8-GAUGE GROUND WIRE DIRECTLY TO THE BATTERY.** The ground path of the bikes frame & electrical system is insufficient to support a high power amplifier like this. Insufficient grounding of this amp, or any other amp for that matter, will result in garbage sound quality and piss-poor performance. Yes, it's that serious, just do it...

1. Remove the seat strap & seat screws with a Phillips screw driver. Store the seat and the screws removed in a safe place for re-installation later.
2. Set aside the ECM tray by removing its two screws with a 1/2" socket. Additional harnesses/connectors that are attached to the tray may need to be removed to set the tray aside. Set the bolts aside for re-installation later.
3. Remove the power & ground cable bolt from the battery with a 10mm socket. Disconnect all power and ground cables and set the bolts aside for re-installation later.
4. Route the power & ground cables from the battery compartment to the amplifier location. Avoid routing the cables over engine components and sharp metal edges. Use cable ties to loosely secure the cables to the frame, brackets, adjacent cables, etc.
5. Cut both cables to length. Strip off about 3/8" (10mm) of the insulation and insert each into its corresponding terminal of the connector. An additional 3/8" of the cables insulation should nest inside the connector, preventing any rogue strands from accidentally shorting. Use a mini Philips screwdriver to tighten the screws of each terminal.
6. Add the amplifiers power cable with all other power cables & re-install the power cable bolt removed in step three to the battery's positive terminal using a 10mm socket. However, leave the in-line fuse out or circuit breaker off until all other cable connections are complete.

7. Add the amplifier's ground cable with all other ground cables & re-install the ground cable bolt removed in step three to the battery's negative terminal using a 10mm socket.
8. Tighten any loosely secured cable ties after all connections are complete. Install the in-line fuse or activate the circuit breaker.
9. Reinstall the ECM tray using the two bolts removed in step two with a 1/2" socket. Reattach any wire harness that were originally attached to the ECM tray.
10. Reinstall the seat to the fender & the seat strap to the fender brackets using the Phillips screws removed in step one.

### **REMOTE TURN-ON WIRE**

Remote turn-on input must be connected to a switched +12V source. Typically, remote turn-on is initiated by the head unit. Look for a blue wire on an aftermarket head unit wire harness. If available, connect the turn-on wire from the head unit to the REM terminal of the power/ground wire connector. If you will keep the factory head unit, you could also connect the remote turn-on of the amp to the purple wire of a P&A connector. There should be a few scattered around the bike, several in the fairing.

### **LOW-LEVEL / RCA INPUT**

We've provided RCA input harness for this amplifier, in the event you are using an aftermarket head unit with RCA outputs, and you feel very strongly about noisy sound & ground loop. Really though, low voltage signal from RCA outputs is susceptible to noise from the various electronic components & wiring in the fairing. If you still want to use the RCA outputs of an aftermarket head unit, connect the front channels (1 & 2) & rear channels (3 & 4) RCA output to a RCA input harness with good quality RCA cables. The white-ish ends of the RCA input harness are for left the channels (1 & 3), and the red ends are for the right channels (2 & 4). Wrap each connection with electrical tape so they won't come apart.

### **HIGH-LEVEL / SPEAKER LEVEL INPUT**

If you're reading this, you make good choices in life, including the choice to use high/speaker level input. We've included universal high/speaker level input wire harnesses to connect to the speaker output of an aftermarket head unit. Connect the pairs of white & black wires to the corresponding speaker wires of your head unit:

White - Front Left (+)	White/Black - Front Left (-)
Grey - Front Right (+)	Grey/Black - Front Right (-)
Green - Rear Left (+)	Green/Black - Rear Left (-)
Purple - Rear Right (+)	Purple/Black - Rear Right (-)

You can use crimp-on wire connectors to join the wires from your head unit to the high-level input connectors provided. However the best connection of these wires is by solder with heat-shrink tubing. Soldering prevents wires from coming apart, and heatshrink tube keeps them waterproof. If you did get the amplifier installation kit, all of this is pre-wired, just plug-in.

**SPEAKER OUTPUT**

You can use crimp-on wire connectors to join the wires from your speakers to the speaker output connector. However, the best connection of these wires is by solder with heat-shrink tubing. Soldering prevents wires from coming apart, and heatshrink tube keeps them waterproof. Each channel's positive (+) and negative (-) wires are color coded for easy identification:

**FRONT SPEAKERS:**clutch side - left

all white is positive (+)

white w/ black stripe is negative (-)

brake side - right

all grey is positive (+)

grey w/ black is negative (-)

**REAR OR LOWER SPEAKERS:**clutch side - left

all green is positive (+)

green w/ black is negative (-)

brake side - right

all purple is positive (+)

purple w/ black is negative (-)

If you used your better judgement and got the amplifier installation kit, all of this is pre-wired, ready to go. Just plug-in. See the recurring theme here...

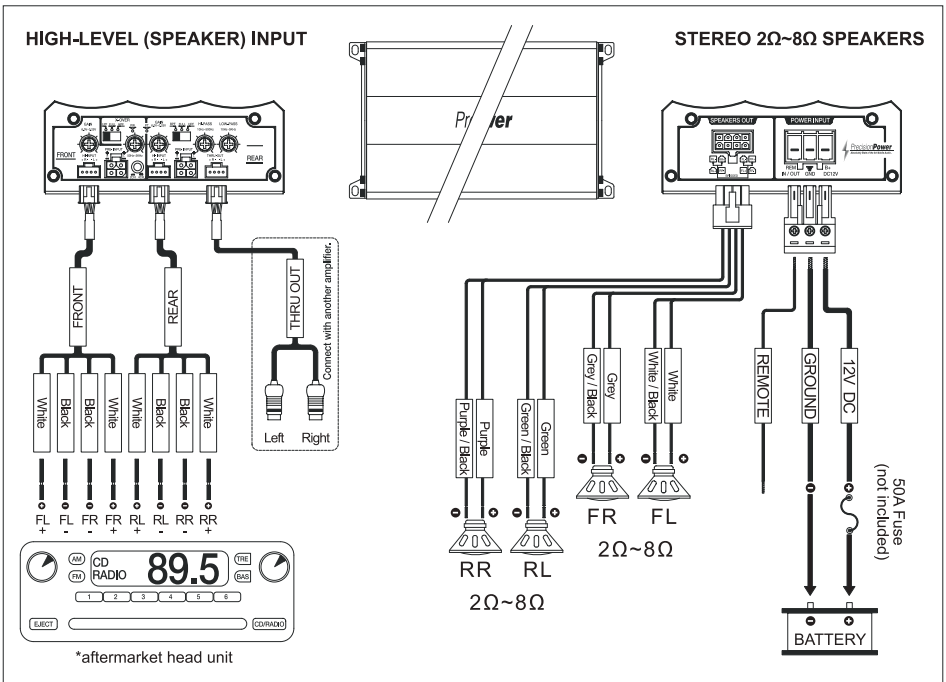
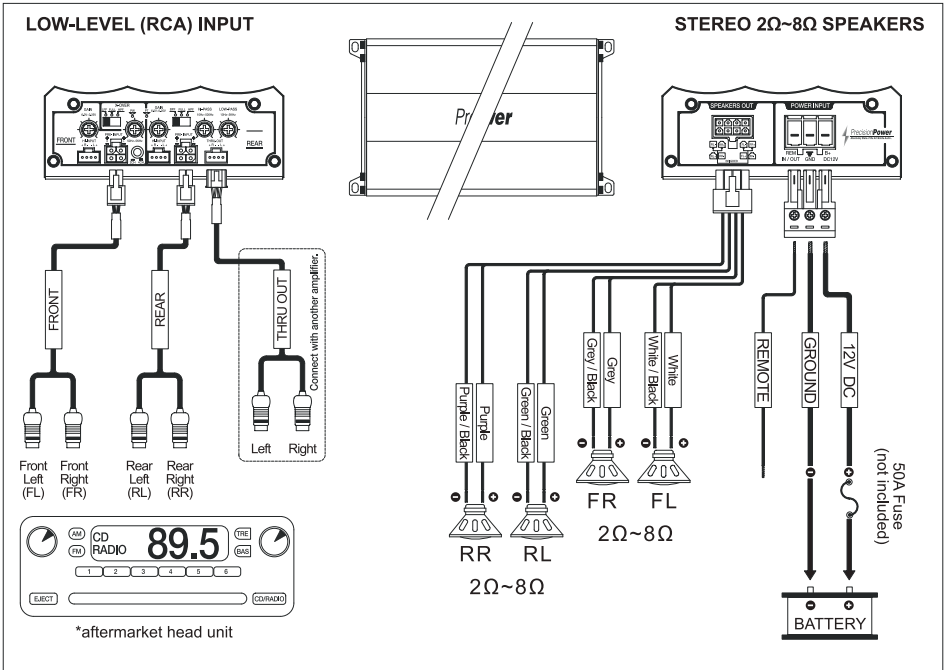

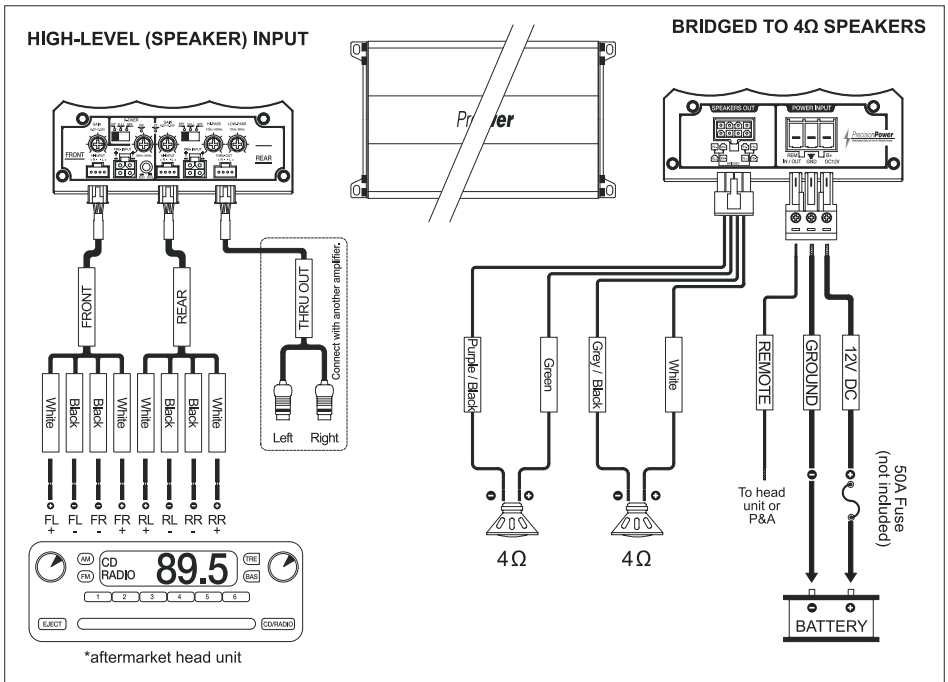
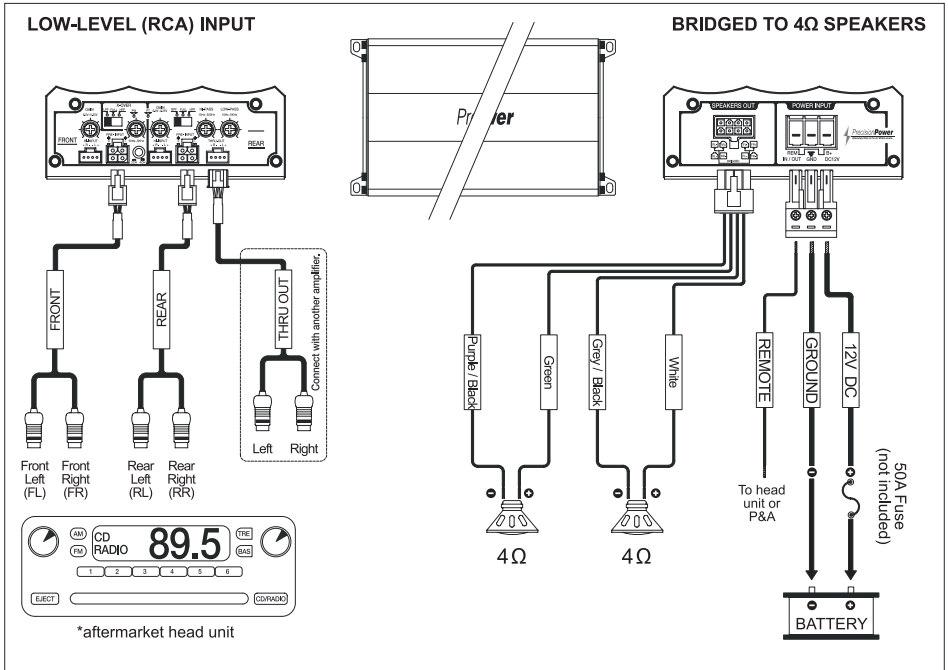

Problem	Solution
<p><b>Power LED not ON</b></p>	<p>With a Volt Ohm Meter (VOM) check:</p> <ul style="list-style-type: none"> <li>• +12 Volt power terminal (should read +12 to +16VDC).</li> <li>• Remote turn-on terminal (should read +12 to +16VDC).</li> <li>• Ground Terminal.</li> </ul>
<p><b>Power LED is GREEN, no output</b></p>	<ul style="list-style-type: none"> <li>• Check RCA connections.</li> <li>• Test speaker outputs with known good speaker.</li> <li>• Substitute known good Source Unit.</li> <li>• Check for signal on the RCA cable with VOM in AC position.</li> </ul>
<p><b>Protection LED is ON, no output and</b></p> <ol style="list-style-type: none"> <li><b>1. Amp is VERY HOT</b></li> <li><b>2. Amp shuts down ONLY when the vehicle is running</b></li> <li><b>3. Amp plays at very low volume</b></li> </ol>	<ul style="list-style-type: none"> <li>• Thermal protection is engaged. Check for proper impedance at speaker terminals. Also check for adequate air flow around the amplifier.</li> <li>• Voltage protection engaged. Voltage to the amp is not within the 10-16.8 VDC operating range. Have the battery/charging system inspected.</li> <li>• Short circuit protection is engaged. Check for speaker wires shorted to each other or the vehicle chassis. Speakers operating below the minimum impedance can cause this to occur.</li> </ul>
<p><b>Alternator noise (varies with RPM)</b></p>	<ul style="list-style-type: none"> <li>• Check for damaged RCA cable.</li> <li>• Check routing of RCA cable.</li> <li>• Check Source Unit for good ground.</li> <li>• Check amp gain setting, turn down if set too high.</li> </ul>
<p><b>Poor Bass Response</b></p>	<ul style="list-style-type: none"> <li>• Check speaker polarity, reverse the connection, of one speaker only.</li> </ul>

**NOTE:** If the RED protection L.E.D. is activated with no speakers connected to the amplifier, and all the power connections are correct, this would indicate an internal problem with the amplifier. Contact Precision Power or your local dealer.

## LIMITED 90-DAY CONSUMER WARRANTY

## LIMITED TWO-YEAR CONSUMER WARRANTY WITH PURCHASE AND INSTALLATION BY A PRECISION POWER AUTHORIZED DEALER

PrecisionPower promises to the original purchaser, to repair or replace this product with a new or refurbished unit (at PrecisionPower's sole and absolute discretion) should it prove to be defective in workmanship or material under normal use, for a period of \*two-years from the date of purchase from the PrecisionPower authorized dealer, PROVIDED the product was purchased and installed by a PrecisionPower authorized dealer. During this \*two-year period, there will be no charge for product repair or replacement, PROVIDED the unit is returned to Precision Power, return shipping pre-paid, along with the required proof of installation, the bill of sale or other dated proof of purchase, and the consumer's contact information.

If the unit is installed by anyone other than a PrecisionPower authorized dealer, the warranty period will be 90-days from the date of purchase. This warranty is non-transferable and does not apply to any unit that has been modified or used in a manner contrary to its intended purpose, and does not cover damage to the unit caused by installation or removal of the unit. During this 90-day period, there will be no charge for the repair or replacement PROVIDED the unit is returned to PrecisionPower, return shipping prepaid, along with the bill of sale or other dated proof of purchase and the consumer's contact information.

This warranty is void if the product has been damaged by accident or unreasonable use, neglect, improper service or other causes not arising out of defects in materials or construction. This warranty does not cover the elimination of externally generated static or noise, or the correction of antenna problems or weak reception, damage to speakers, accessories, electrical systems, cosmetic damage or damage due to negligence, misuse, failure to follow operating instructions, accidental spills or customer applied cleaners, damage due to environmental causes such as floods, airborne fallout, chemicals, salt, hail, lightning or extreme temperatures, damage due to accidents, road hazards, fire, theft, loss or vandalism, damage due to improper connection to equipment of another manufacturer, modification of existing equipment, or Product which has been opened or tampered for any reason. Units which are found to be damaged by abuse resulting in thermally damaged voice coils are not covered by this warranty but may be replaced at the absolute and sole discretion of PrecisionPower. Unit must be returned to PrecisionPower, postage pre-paid, with bill of sale or other dated proof of purchase bearing the following information: consumer's name, telephone number, and address, authorized dealer's name and address, and product description. Please contact PrecisionPower's warranty office at 800-724-1377 or [repairs@PrecisionPower.com](mailto:repairs@PrecisionPower.com) to obtain a Return Authorization number prior to shipping the product.

Note: This warranty does not cover labor costs for the removal and reinstallation of the unit. IN ORDER FOR THE TWO-YEAR WARRANTY TO BE VALID, YOUR UNIT MUST BE SHIPPED WITH PROOF OF INSTALLATION BY A PRECISIONPOWER AUTHORIZED DEALER. ALL UNITS RECEIVED BY PRECISIONPOWER FOR WARRANTY REPAIR WITHOUT PROOF OF PRECISION POWER AUTHORIZED DEALER INSTALLATION AND PURCHASE WILL BE COVERED BY THE LIMITED 1 YEAR WARRANTY.

BY PURCHASING THIS PRODUCT, ALL WARRANTIES INCLUDING BUT NOT LIMITED TO EXPRESS WARRANTY, IMPLIED WARRANTY, WARRANTY OF MERCHANTABILITY, FITNESS FOR PARTICULAR PURPOSE, AND WARRANTY OF NON-INFRINGEMENT OF INTELLECTUAL PROPERTY ARE EXPRESSLY EXCLUDED TO THE MAXIMUM EXTENT ALLOWED BY LAW, AND PRECISIONPOWER NEITHER ASSUMES NOR AUTHORIZES ANY PERSON TO ASSUME FOR IT ANY LIABILITY IN CONNECTION WITH THE SALE OF THE PRODUCT. PRECISION POWER HAS ABSOLUTELY NO LIABILITY FOR ANY AND ALL ACTS OF THIRD PARTIES INCLUDING ITS AUTHORIZED DEALERS OR INSTALLERS. BY PURCHASING THIS PRODUCT, THE CONSUMER AGREES AND CONSENTS THAT ALL DISPUTES BETWEEN THE CONSUMER AND PRECISIONPOWER SHALL BE RESOLVED IN ACCORDANCE WITH CALIFORNIA LAWS IN LOS ANGELES COUNTY, CALIFORNIA. Some states do not allow limitation on how long an implied warranty lasts. In such states, the limitation or exclusions of this Limited Warranty may not apply. Some states do not allow the exclusion or limitation of incidental or consequential damages. In such states, the exclusion or limitation of this Limited Warranty may not apply to you. This Limited Warranty gives you specific legal rights, and you may have other rights which vary from state to state.